

Riverside Manual

Prepared October 2021

Riverside Manual

First and foremost.

1. Check that the band is booked for the correct night and confirm how much they will be charging and for how long they will be playing between the hours of 8.00pm and 11.00pm, and how long will their break will be and when. It will affect when the raffle is drawn.
2. Decide on the price of the tickets, whether children are welcome, and how many you will require. In the past it has been 300.
3. Ensure **Brian Percival** is informed of the band name, the date of the event and how much the tickets will cost and other relevant information regarding graphics.
Tel. 860988. Email brianpercival47@gmail.com
He will make the necessary amendments to the art work, prior to arranging for the printing from 'Instant Print' of the A1 posters to be fixed to the profiled double sided 'music' signs, the A3 and A4 promotion posters, and the tickets.
4. **Towards the end of May start to promote the event on all fronts.**
5. **Campie** will, about this time, if not before, contact various companies, dining establishments, and pubs who might offer 'Prizes' for the raffle.
6. The large double sided roadside signs are the first to be erected. They are to be found in **Janet Troake's barn** adjacent to Rull Farm at the top of Rull Hill, along with the mobile stage and other props. We would normally erect these in the **first week of June.**
7. **The Double sided signs are to be located in the following places.**
 - A. On the Witheridge to Chawleigh road at the western extremity of Burrow Moor Cottage. (Lou & Amanda's place)
 - B. Three Hammers X, on the south side near the sign post.
 - C. At the entry into Witheridge, from Tiverton, adjacent to the 30 mph sign, without obscuring any other signs.
 - D. At Burrow X, On the NW quadrant adjacent to the bungalow. the ground is softer there.
 - E. On the B3137 at the turn to West Yeo Farm on the SW quadrant.
 - F. At Thelbridge X, on the south side near the sign post**The single sided signs are to be located as below**
 - G. On the railings on Drayford Green facing the road from East Worlington.
 - H. On the gate into the 'Site'
8. Print off A3, A4 posters and flyers, the numbers of which, to be established by **Campie**, who will then carefully laminate the posters before locating or distributing them for display in selected shop windows, or on village notice boards etc.
9. Notify by email all those people who attended the event in 2019 encouraging them to buy their tickets early, together with reserving there 'Gazebo Space'.EWPH admin. will have names and email addresses of those who bought tickets via the website.
10. Ask Campie to notify her 'list of 900+ close personal friends'. to the same end.
11. Ensure an advert has been placed in the monthly Witheridge news letter and the equivalent serving Chulmleigh
12. Arrange for 3 mobile toilets to be delivered to site in the week before the event.....usually organised by Campie.
13. Speak with **Richard Boyles, Dart Electrics**, regarding the loan of the flood lighting used at previous events and for his possible assistance in connecting it to the power supply of Edgelake Cottage and bringing it across Edgelake Bridge to 3 the distribution boards.

The Double Sided Road Sign

Plywood instrument sign

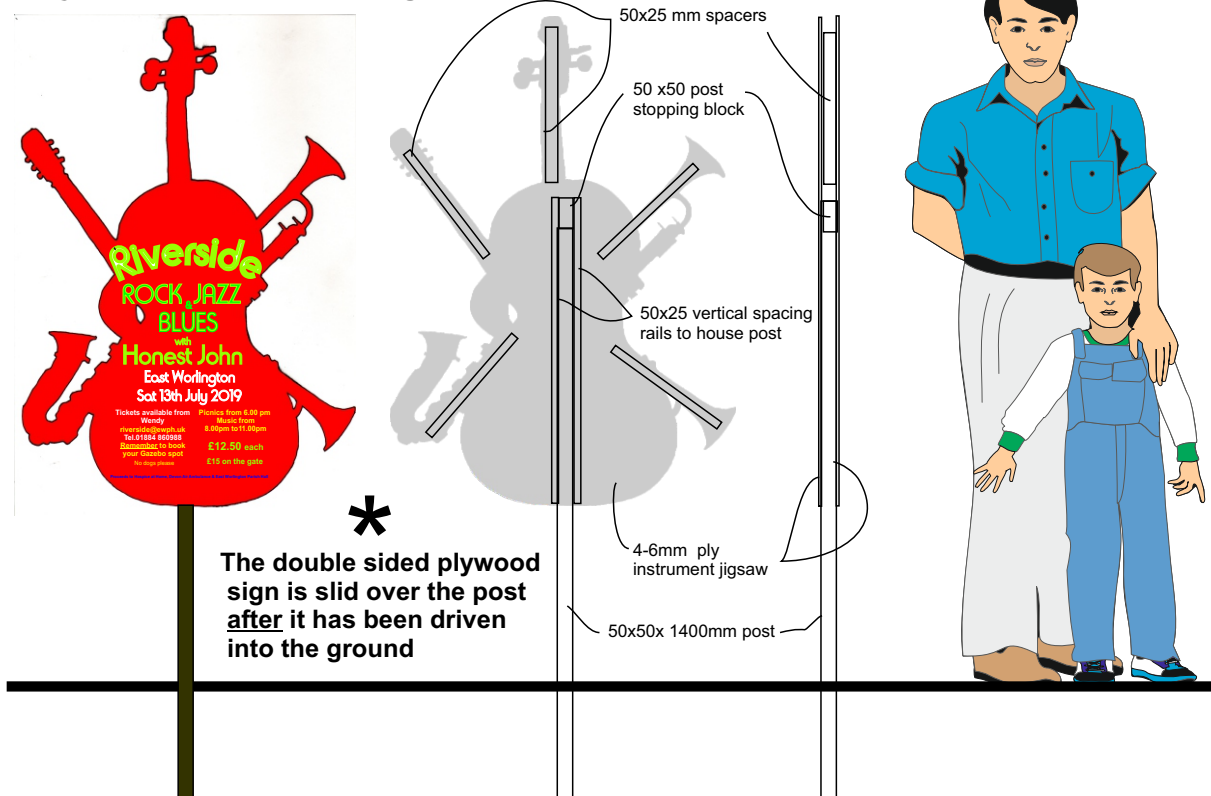

Riverside
ROCK & JAZZ
& BLUES
 with
Honest John
 East Worlington
 Sat 13th July 2019

Picnics from 6.00pm		Tickets available from
Music from 8.00pm to 11.00pm	£12.50 each	Wendy
Remember to book your Gazebo spot	£15 on the gate	riverside@ewph.uk
		Tel.01884 860988

No dogs please
 Proceeds to Hospicecare@Home, Devon Air Ambulance & East Worlington Parish Hall

Riverside
ROCK & JAZZ
BLUES
 with
Honest John
 East Worlington
 Sat 13th July 2019

Tickets available from Wendy	Picnics from 6.00 pm
riverside@ewph.uk	Music from 8.00pm to 11.00pm
Tel.01884 860988	£12.50 each
Remember to book your Gazebo spot	£15 on the gate

No dogs please
 Proceeds to Hospicecare@Home, Devon Air Ambulance & East Worlington Parish Hall

This 2019 design was used for the A3 & A4 posters, A6 flyers and A7 Tickets

This 2019 design printed at A2 was used and trimmed to fit the double sided road signs above.

Other incidental signs required on the day

14. Smaller directional signs are erected on the day of the event to guide people over the last few twists and turns they have make to arrive at the venue.
- A. Thornham Cross
 - B. Drayford
 - C. East Worlington



....and finally the Car Park entry signs



- 15 Once Campie has finalised the Raffle prizes a bespoke sign needs to be made designed and made before the night and attached to hanging board.

RAFFLE PRIZES

1		Food Hamper with Free Range Chicken from Debbie Atwell and much much more	
2		£60 Voucher the award winning Restaurant LA PETITE BOUCHEE The Square Witheridge	
		Two for the price of one Two course lunch The Stag Rackenford	
4		£25 Gift Voucher THE MOUNT PLEASANT INN NOMANSLAND	
5		£20 Gift Voucher Withleigh Nurseries Withleigh Sharing our passion for plants	
6		Liz Morris Nomansland Dog training lesson	

7		WAX WASH	
8		Ash Moor Nursery Rose Ash	
9		HONEY COLLECTION Natural beauty, naturally	
10		A GOODY BAG from THE VILLAGE HAIR SHOP Witheridge	
11		Box of Wine	
12		Pamper Basket	

The illustration below shows the final layout on the night in 2019

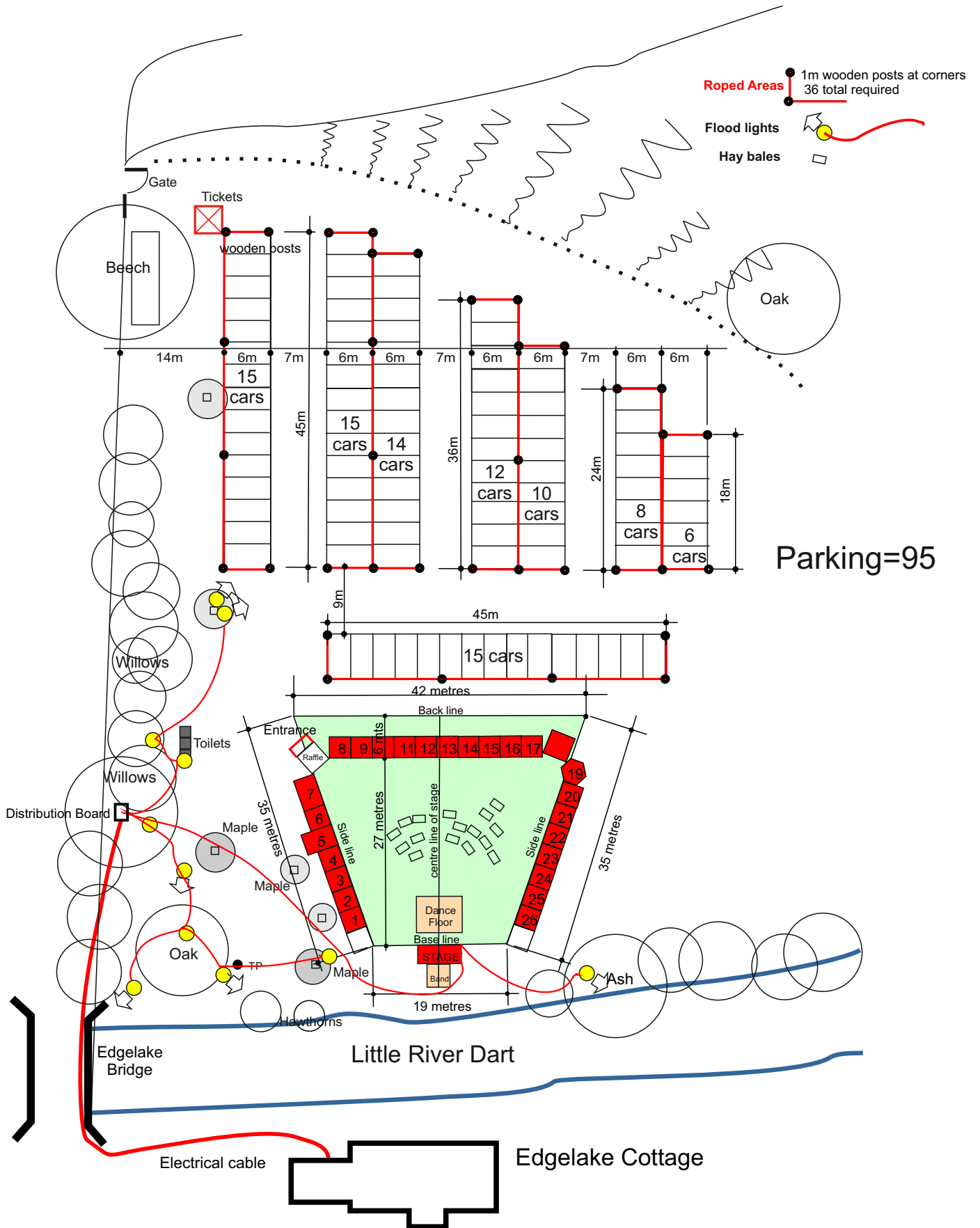

The week running up to the night of the performance.

1. Contact **Phil Brown at Halse Farm** and ask when he may be able to bring the Mobile stage to site. He will use his tractor for this as the stage was once an old hay trailer. He will place this in the field opposite Edgelake Cottage with the stage facing away from the river. It will be loaded with plywood sheets and bearers, which will make up the dance floor, together with the blocks and stage lighting, road signs. **Level up the stage using the blocks.**



2. Setting out the Arena (I would suggest three days before the night)

Having positioned and levelled the stage, mark out with temporary posts the **setting-out lines** for positioning the gazebos. The **Base Line**, the **Centre Line**, the **Back Line**, the **Side Lines** and the **line of the gazebos facing the stage**

- A. The '**Base line**' runs parallel and along the front of the stage. It is **19m** long and sits central to the stage.
- B. Set up a 2nd line at right angles to the **Base line** from the centre of the stage. This the '**Centre Line**'
- C. Along the **Centre line** mark a point at **27m** from the **Base line**, and another at **33m**. The first mark is the '**front line of the gazebos facing the stage**' and the second is the '**Back Line**', the limit of the site.
- D. At both these points set up a 3rd & a 4th line, both running parallel to the **Base line** and centred on the **Centre line**, the first to be **30m** long (The front line of the Gazebos) and second to be **42m** long, the '**Back line**'.
- E. Now draw lines between the end points of the **Base line** to the end points of the **Back line** to form a trapezium. (shown in green) These are the '**Side Lines**' These should measure approximately **35m** and form the front lines of the gazebos to the left and the right of th stage.

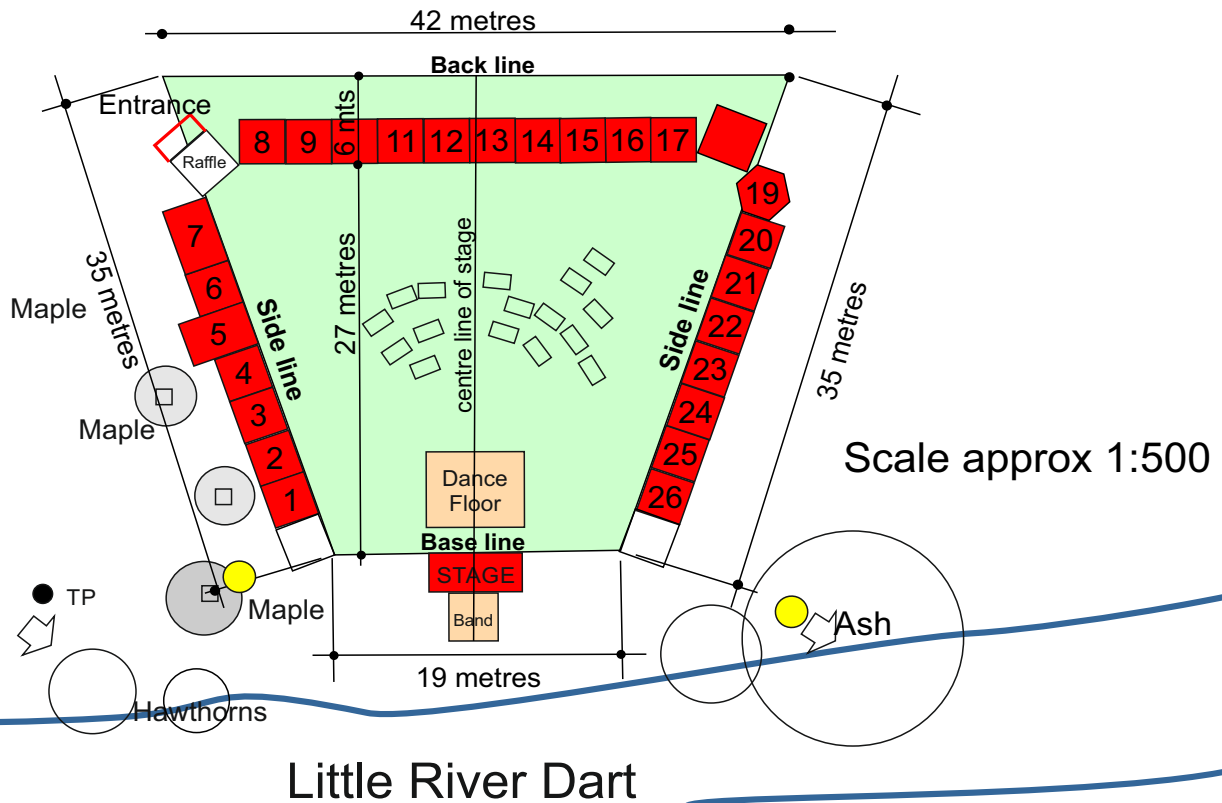

3. We have now created three lines along which the gazebos are to be positioned. As each are generally 3m square, we allocate a space for each using a wooden peg painted white and numbered, which are driven into the ground at approx 3m apart. (these are in a box on the stage). The two spaces shown white on the plan (closest to the stage) are to allow some tolerance and it is not possible to see the stage from these locations. Occasionally people will have a gazebo 3m x 4.5 m which we fit in by turning it through 90 degrees. (see gazebo 5) Octagonal ones are squeezed in at the corners (see 19) Gazebos are to be erected on the day before the event or no later than 5.00 pm on the day. Someone will need to be on hand at all times to advise people which pitch they have been allocated and to help if necessary.

3. Setting out the carparking (2 days before the event)

1m wooden posts at corners
Roped Areas 36 total required
 Flood lights

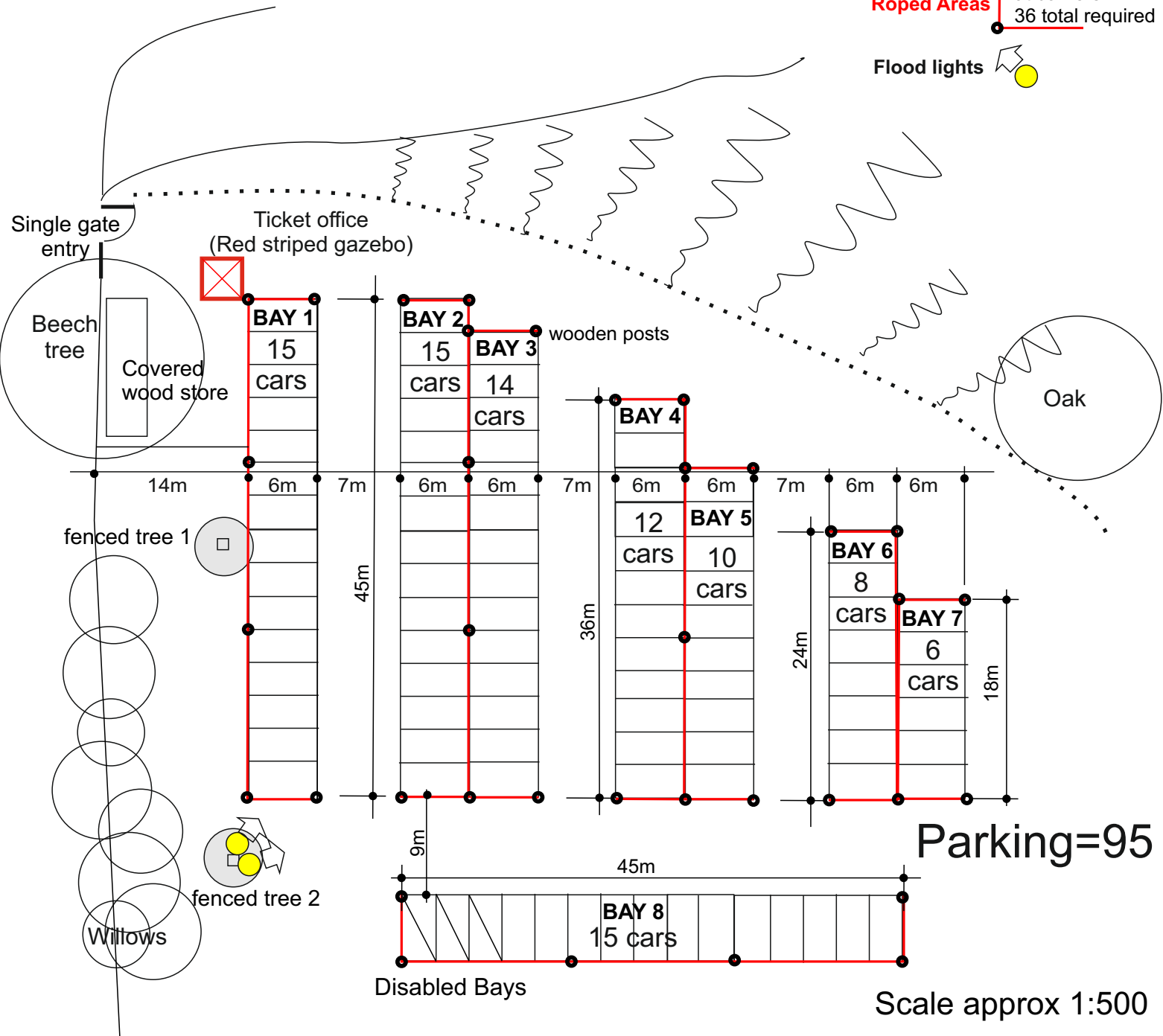

Parking=95

Scale approx 1:500

- Commence by setting up a line running parallel to the road 14m distant. Ensure it runs clear of the two fenced trees. Set out the first bay (**BAY 1**), for 15 cars, using 6 wooden posts and fix rope where indicated by the red lines. This bay measures 45mx 6m. Repeat this process as indicated on the plan for the remaining 6 parallel bays reducing them as indicated each for a lesser number of cars, the last one being for 6 cars. In a similar manner set up the final bay (**BAY 8**) for a further 15 cars at right angles to the previous bays in the position shown. Indicate that the 3 parking spaces closest to the arena are for the disabled. This will provide sufficient parking for 95 cars, giving each car a space of 6m x 3m.

4. The Electrics and lighting (The day before the event)

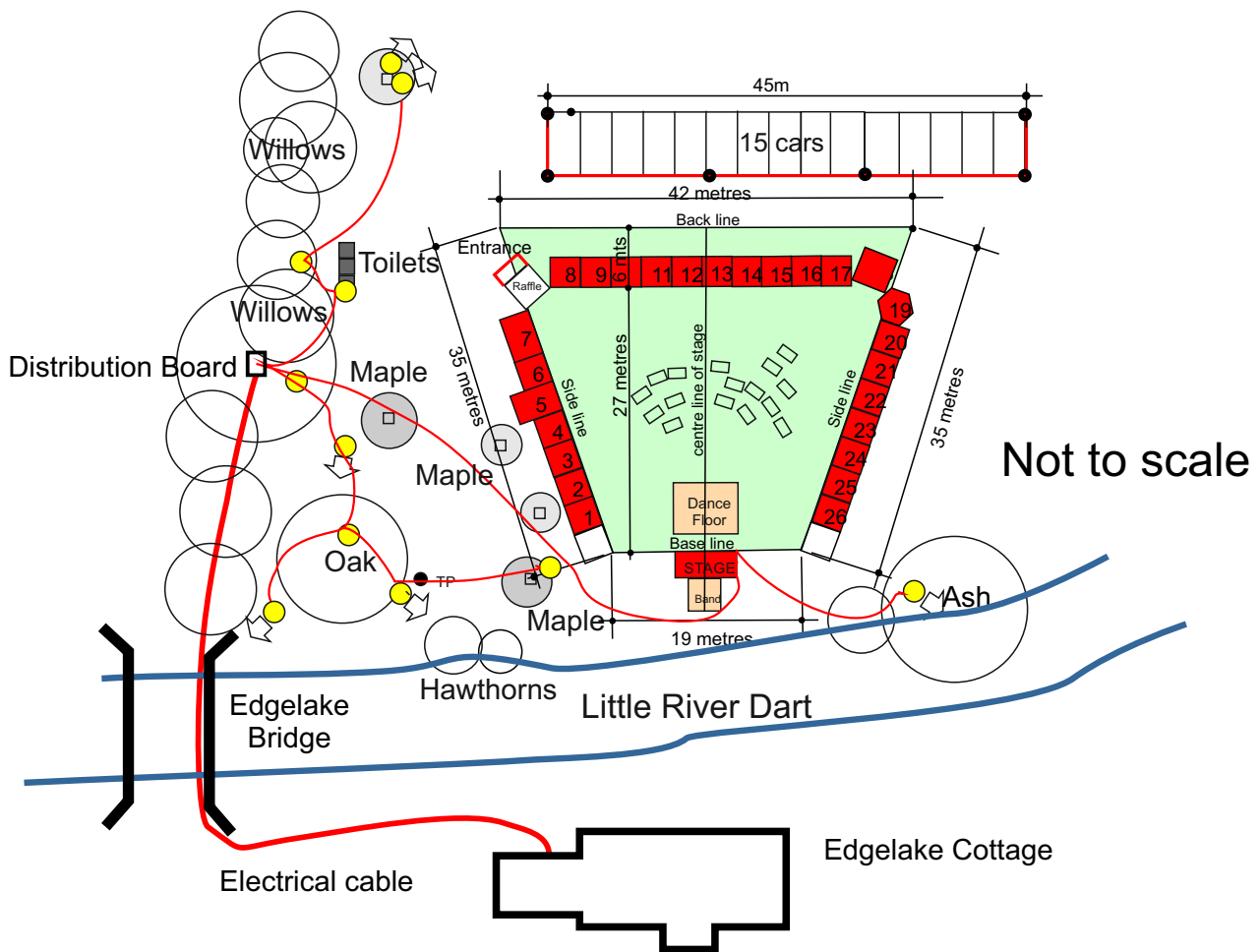

5. Having already contacted Richard Boyles of Dart Electrics, he should be aware of the dates and your requirements. Depending on how busy he is, or where he is working, he may drop off the cabling and flood lights or you may have to collect them from his store in Witheridge.

The principle cable is run from a dedicated power point on the outside wall of Edgelake cottage, across the bridge and through the little pedestrian gate to a distribution board, secured to one of the large tree trunks near the road.

In the past he has provided a selection of heavy duty cables with 16A water proof connections which plug into this distribution board and serve a selection of flood lights.

A separate connection is also run from this distribution board to another distribution board fixed to the inside of the back wall of the stage. This provides 4 power outlets for the band and a spare for further floodlighting along the river.

The setting up of the electrics needs to be done on the day before the event, and the lights placed in the positions indicated, during daylight hours.

The lights with arrows are directional. Those without arrows are shone straight up into the trees, for best effect.

However two people will need to return to site as it starts to get dark and experiment a little with the positioning to be sure they are all angled correctly.

They probably won't finish this task much before midnight!

The Rest!

6. The Ticket Office

This comprises of a striking red and white striped Gazebo with sides to match. This is located adjacent to the Main Entrance gate and is positioned to touch the corner post of the first parking bay, BAY 1. This prevents punters try to gain vehicular access to the rear of their gazebo during the evening, by squeezing behind the framed trees and driving over the electrical cabling and the connections. Not good!

A couple of tables from the hall and 3 chairs would suffice. See 'Box Office' notes for details of the procedure on the night.

Only one gate is used, so that cars and occupants can be dealt with one at a time.

Generally there would need to be 2-3 persons dealing with seeing that the cars are parked sensibly.

The red & white gazebo is borrowed from Brian & Wendy.

7. The Entrance to the 'Arena'

A plain dark blue gazebo, borrowed from Patrick & Rosie Brook has been used in the past. This is erected diagonally across the NW corner of the Arena and a large 'Entrance' banner (supplied) is erected high above it, so it can be seen from the car park. A couple of tables and chairs are required here to display raffle prizes and to accommodate helpers selling raffle tickets as punters arrive.

8. The Band's Gazebo

A further gazebo will need to be erected at the rear of the stage together with two tables and half a dozen chairs. The band are then able to use this area as their base and take refreshments there during their break. The committee will be providing the refreshments. Upon their arrival band members will be directed around the back of the car park where they can drive right up to the back of the stage.

9. The Toilets

This is very much Campie's department. She has in the past ordered the 3 toilets and agreed a time for their delivery during the week before the event. If the ground is dry they can be brought right up to the position shown on the site layout, adjacent to the Arena entrance and will be collected after the weekend. If not, they can be dropped off at the gate and easily dragged into position.

A pathway leading from the Arena entrance to the toilets is to be demarked by either solar lights or candles within glass jars. These should all be found on the stage when it is brought down from the barn.

Remember the solar lights will have need to be pre-charged for a couple of days in sunlight!

10. The Dance floor

To date the Dance floor has comprised of 10 sheets of 12mm plywood screwed down to 100x50 bearers laid flat on the grass. It has worked very well. Plenty of bounce!

However last time out it seemed a little small as towards the end of the night everybody was on the dance floor. So it was suggested after the 2019 event that the dance floor is increased from 6m x 4.8m to 6m x 6m, which will mean the purchase of 5 more sheets of 12mm ply, and the respective bearers.